

# VOLVO PENTA

## VOLVO PENTA INBOARD DIESEL

# D13-700/800/900/1000

12.8 liter, in-line 6 cylinder



### Technical Data

Engine designation	D13-700	D13-800	D13-900	D13-1000
No. of cylinders and configuration	in-line 6	in-line 6	in-line 6	in-line 6
Method of operation	4-stroke, direct-injected, turbocharged diesel engine with charge air cooler			
Bore/stroke, mm (in.)	131/158 (5.16/6.22)	131/158 (5.16/6.22)	131/158 (5.16/6.22)	131/158 (5.16/6.22)
Displacement, l (in <sup>3</sup> )	12.78 (779.7)	12.78 (779.7)	12.78 (779.7)	12.78 (779.7)
Compression ratio	17.1:1	17.1:1	17.1:1	17.1:1
Dry weight bobtail, kg (lb)	1625 (3583)	1625 (3583)	1630 (3594)	1635 (3605)
Crankshaft power, kW (hp)	515 (700) @2250 rpm	588 (800) @2300 rpm	662 (900) @2300 rpm	735 (1000) @ 2400 rpm
Max. torque, Nm (lbf.ft)	2641 (1948) @1400 rpm	3029 (2234) @1800 rpm	3304 (2437) @1500 rpm	3528 (2602) @ 1800 rpm
Emission compliance	IMO NOx, EU RCD Stage II, US EPA Tier 3			
Rating	R2	R3	R4	R5
Recommended fuel to conform to	ASTM-D975 1-D & 2-D, EN 590 or JIS KK 2204			
Flywheel housing/SAE size	14"/SAE1	14"/SAE1	14"/SAE1	14"/SAE1

Technical data according to ISO 8665. With fuel having an LHV of 42700 kJ/kg and density of 840 g/liter at 15 °C (60 °F). Merchant fuel may differ from this specification which will influence engine power output and fuel consumption.

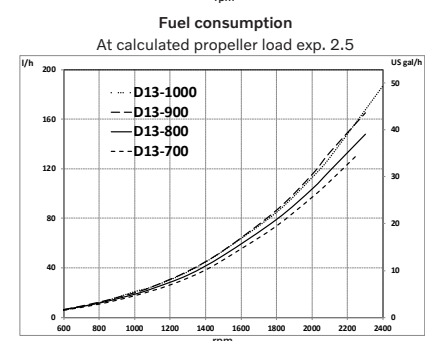
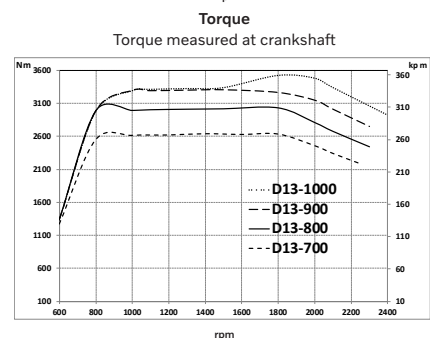
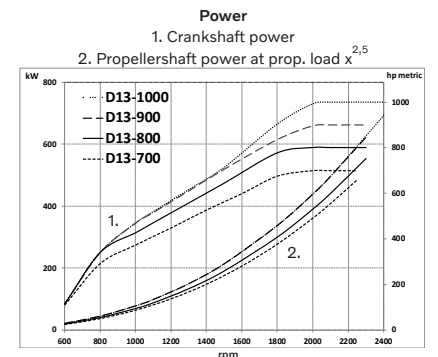

# D13-700/800/900/1000

12.8 liter, in-line 6 cylinder

## Technical description

### Engine and block

- Cylinder block made of cast iron
- One-piece cast-iron cylinder head
- Ladder frame fitted to engine block
- Replaceable wet cylinder liners and valve seats/guides
- Drop forged crankshaft with induction hardened bearing surfaces and fillets with seven main bearings
- Four-valve-per-cylinder layout with overhead camshaft and center position of unit injectors
- Each cylinder features cross-flow inlet and exhaust ducts
- Monotherm steel pistons
- Rear-end transmission

### Engine mounting

- Flexible engine mounting

### Lubrication system

- Integrated oil cooler in cylinder block
- Rear positioned twin full flow oil filter of spin-on type and by-pass filter

### Fuel system

- Electronic high pressure unit injectors
- Gear-driven fuel pump and injection timing
- Electronically controlled central processing system (EMS – Engine Management System)
- Single fine fuel filter of spin-on type

### Air inlet and exhaust system

- Twin entry turbo technology with freshwater-cooled charge air cooler
- Air filter with replaceable inserts
- Wet exhaust elbow (option)
- Loss of sea water alarm

### Cooling system

- Seawater-cooled plate heat exchanger
- Coolant system prepared for hot water outlet
- Easily accessible seawater pump in rear end of flywheel housing

### Electrical system

- 24V/110A plus an optional extra 12V/115A alternator



### Electronic Vessel Control (EVC)

- Fully integrates the engines, electronics and the unique set of EVC features; Joystick Docking (available for twin engine installations), Glass Cockpit and more

### Gear box

- ZF500-1A-E and ZF500-1IV-E, with low speed as option, electronically shifted
- ZF-400A, with low speed as standard, electronically shifted
- Connection kits for Twin disc available

## Dimensions D13-800 with ZF400A

Not for installation

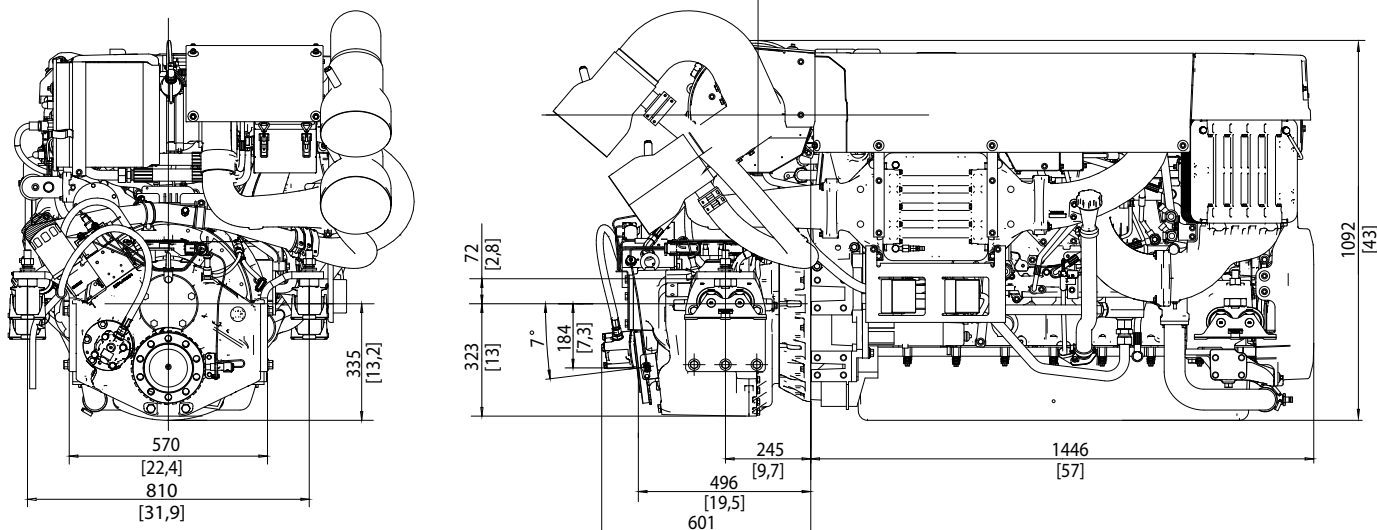

Not all models, standard equipment and accessories are available in all countries. All specifications are subject to change without notice. The engine illustrated may not be entirely identical to production standard engines.

Contact your local Volvo Penta dealer for more information regarding Volvo Penta engines and optional equipment/ accessories or visit [www.volvopenta.com](http://www.volvopenta.com)



**AB Volvo Penta**

SE-405 08 Göteborg, Sweden  
[www.volvopenta.com](http://www.volvopenta.com)