

SANY[®]

SANY DIESEL TRUCK 6 X 4

UAE
KQY100001061

Quality changes the world

■ www.sanyglobal.com

© Version 2026-03-28



Read E-brochure



Contents

SANY DIESEL TRUCK
UAE 6x4 VERSION

01 Basic
Configuration

02 Core
Advantages

03 Application Scenarios
& Cases

04 Services
Support

01 Basic Configuration

	Items	Technical Specifications
Basic Parameter	Model	HQC343DE1
	Driver's Seat Location	Left Hand Drive
	Drive Type	6×4
	Curb Weight (kg)	10500
	Gross Combination Weight (kg)	110000
	Maximum Speed (km/h)	89(Speed Limited)
	Emission Standard	EURO V
Engine	Model	D13C5-525E2
	Rated Power	525 HP/386 kW
	Peak Torque (N·m)	2550
Transmission	Model	F16JZ26A+QHG100B(Optional F12JZ26A+QHG100B)
	Transmission Control System	AMT
	Fwd/Rev Speed Configuration	16/2(Optional 12/2)
Drive Axle	Load Capacity(t) and Ratio	16/16, 4.769(Optional 4.266)
Brake	Type	Front and Rear Drum
Auxiliary Braking	Type	Engine Cylinder Brake
Suspension	Type	Front 9 Leaf Spring, Rear 10 Leaf Spring
Fuel Tank	Volume (L)	700, Honeycomb Air Filter (Optional-400L, Desert Air Filter)
Wheel	Wheel Rim	Front and Rear Steel
	Tires	12.00R24

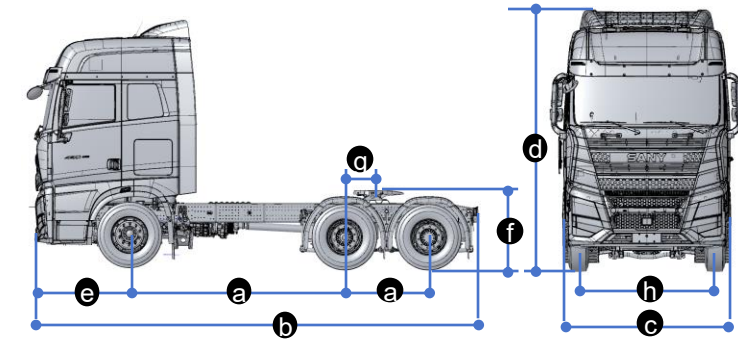

a	Wheelbase	3225+1400mm
b	Length	6965mm
c	Width	2545mm
d	Height	4090mm
e	Front overhang	1590mm
f	Fifth Wheel Height (Unloaded)	1470mm±20mm
g	Fifth Wheel Position	375mm
h	Wheel Track	2118/1884/1884mm

01 Basic Configuration

Intelligent
Driving System



ABS

ASR

Cabin Type



High roof flat floor LHD cabin

7-inch instrument panel & 12.1-inch central control touchscreen

Automatic adjustable rear mirror with electric heating function

Rear window

External sunshade

Electric air conditioning

Adjustable Seat

Power windows

02 Core Advantages



Exceptional Power

High torque, power surging

- ◆ The German-engineered Deutz D13C5-525 engine, boasting an impressive 525 HP and 2550 N·m, offers **superior power advantages over competitors**



High Reliability

≥ 1 million km service life

- ◆ Vehicle components boast improved performance, with rust-proof, dust-proof and waterproof rating **meeting C5 standard**
- ◆ Vehicle passed million-kilometer durability validation, proving **service life ≥ 1 million km**



High Security

30% vehicle's active safety performance enhancement

- ◆ Standard in ABS+ASR, and driver fatigue monitoring, intelligent technologies boost the vehicle's **active safety performance by 30%**
- ◆ The cab and body feature an all-steel integrated design, with safety performance meeting and exceeding ECE R29 requirements. The paint film thickness is significantly higher than industry standards, delivering **superior corrosion resistance and durability**



High Passability

≥ 500 mm bumper ground clearance

- ◆ The high-mounted bumper features a ground clearance of up to 500 mm, ensuring **excellent passability in complex road conditions**
- ◆ Rotational speed differential functions for drive axle and drive wheel, and ASR ensure **reliable passability of unpaved roads**

02 Core Advantages

Gold-Powered Drive System

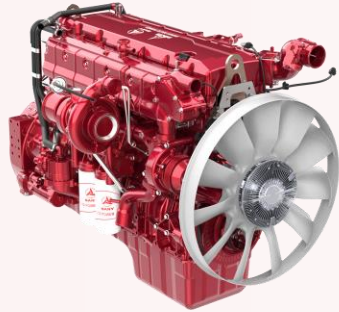

SANY Deutz engine

- ✓ DEUTZ, a century-old brand, features the European latest advanced technology with strong overload capacity and superior durability
- ✓ High-efficiency turbocharger and high explosion pressure combustion technology deliver stronger power output, with more robust performance during startup and sudden acceleration

Efficient transmission performance & Stable output



FAST gear transmission

- ✓ FAST's new-generation integrated automatic transmission balances power performance across both high and low speed ranges
- ✓ High-precision gear grinding technology achieves a transmission efficiency of up to 99.8%
- ✓ Equipped with economic/sport dual driving modes, it features smooth shifting and easy operation

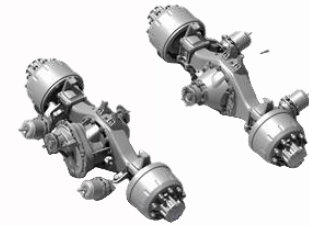

FANGSHENG /
HANDE axle

- ✓ FANGSHENG/HANDE axle features superior load capacity, high quality and reliability
- ✓ A broad range of gear ratio options enables adaptation to diverse operating conditions, including highway and national road scenarios

03 Application Scenarios & Cases



Sand and gravel transportation

Segment market	Sand and gravel transportation
GCW	110 t
Maximum speed	89(speed limited) / 108 km/h (speed unlimited)
Transportation scenarios	Sand and gravel; Cement



Highway sand and gravel transportation



03 Application Scenarios & Cases



Countries :UAE

Scenarios : Sand and gravel

Number of Deliveries : 13 units

04 Technical Support & Services



A. Service network

SANY Efficient Service Supply Network

24/7 Service Online



1,700+

Overseas Service Centers

7,000+

Professional Service Staff

24h

24/7 Always Online

Prompt SANY Standard Service Response

“12127” Service Target



1 quarter Respond

2 hours Arrival

1 day General Issues Solved

2 days Complaint Issues Solved

7 days Legacy Issues Solved

Parts Support

“1790” Parts

Target



1 day Downtime Parts Shipped within 1 Day

7 days Urgent Parts Shipped within 7 Days

90% Local Parts Availability

04 Services Support

B. Service Policy

A. Vehicle Warranty Policy

For SANY trucks in overseas markets, the standard warranty period for all vehicle parts (excluding critical components and special warranty items) is **two-year with unlimited mileage**

B. Key Components Warranty Policy

For Standard Model

- **Automatic transmission assembly**
(Casting Parts follow the base warranty period): **36 months**
- **Manual transmission assembly**
(Housing Parts follow the base warranty period): **36 months**



Transmission

- Lifting Axle, Support Axle Tube & Axle Housing Assembly, Bearing Block, Transfer Case Cover, Transfer Case, Oil Seal Seat: **36 months**



Axles

- Basic components(excluding Crankshaft, Camshaft, Connecting Rod, Flywheel Housing, Gear, Timing Gear Chamber): **36 months**



engine

For Super Model

- Automatic transmission assembly (Casting Parts follow the base warranty period): **24 months**

- Lifting Axle, Support Axle Tube & Axle Housing Assembly, Bearing Block, Transfer Case Cover, Transfer Case, Oil Seal Seat: **24 months**

- Basic components(excluding Crankshaft, Camshaft, Connecting Rod, Flywheel Housing, Gear, Timing Gear Chamber): **24 months**

C. Parts Warranty Policy

Components purchased by customers through parts stores or service centers are covered by a **6-month** SANY parts warranty

For specific component warranty periods, please refer to *SANY Detailed Rules for Quality Warranty Periods*.

thanks

SANY TRUCK



 www.sanyglobal.com | www.sanytruck.com/intl/



Follow SANY Group



Follow SANY TRUCK