

**SANY**<sup>®</sup>

**SANY DIESEL TRUCK**  
**4 X 2**

**LEAF SPRING VERSION**

Quality changes the world

---

■ [www.sanyglobal.com](http://www.sanyglobal.com)

© Version 2026-03-28

---



Read E-brochure

**Saudi Arabia**  
**KQY100001076**



# Contents

SANY DIESEL TRUCK  
Saudi Arabia 4x2 Leaf Spring Version

**01** Basic  
Configuration

**02** Core  
Advantages

**03** Application Scenarios  
& Cases

**04** Services  
Support

# 01 Basic Configuration

Items		Saudi Arabia 4x2 Leaf Spring Version Technical Specifications
<b>Basic Parameter</b>	Model	HQC41800SWS13E40C
	Driver's Seat Location	Left Hand Drive
	Drive Type	4×2
	Curb Weight (kg)	7500
	Gross Combination Weight (kg)	45000
	Maximum Speed (km/h)	89(Speed Limited)
	Emission Standard	EURO V
<b>Engine</b>	Model	D13C5-485E2
	Rated Power	485HP/357kW
	Peak Torque (N·m)	2350
<b>Transmission</b>	Model	F12JZ24A+QHG50C(FAST)
	Transmission Control System	AMT
	Fwd/Rev Speed Configuration	12/2
	Gear Ratios	1st:12.26;12th:0.78
<b>Drive Axle</b>	Load Capacity(t) and Ratio	13, 3.866(Optional 4.266)
<b>Brake</b>	Type	Front and Rear Drum
<b>Auxiliary Braking</b>	Type	Engine Cylinder Brake
<b>Suspension</b>	Type	Front 3 Leaf Spring, Rear 4+3 Leaf Spring
<b>Fuel Tank</b>	Volume (L)	500+300
<b>Wheel</b>	Wheel Rim	Front and Rear Steel
	Tires	Front 385/65R22.5, Rear 315/80R22.5

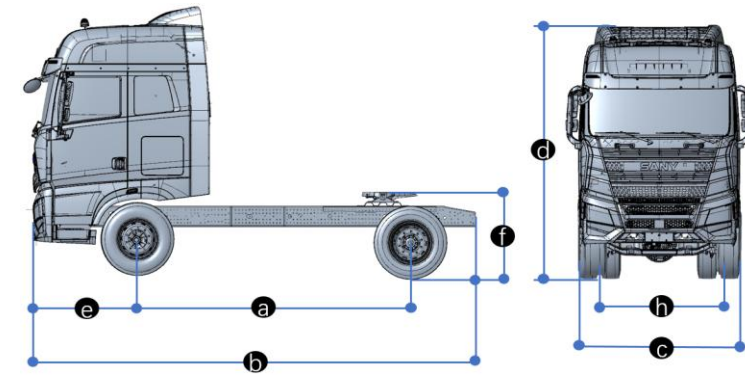

<b>a</b>	Wheelbase	4000mm
<b>b</b>	Length	6465mm
<b>c</b>	Width	2550mm
<b>d</b>	Height	3935mm
<b>e</b>	Front Overhang	1515mm
<b>f</b>	Fifth Wheel Height (Unloaded)	1270±20mm
<b>h</b>	Wheel Track	2059/1864mm

# 01 Basic Configuration

Intelligent  
Driving System



ABS

ASR

Cabin Type



High roof flat floor LHD cabin



7-inch crystal instrument panel & 12.1-inch central control touchscreen

Wind deflector

Double-deck berths

Driver's air suspension seat

Warning lights

Automatic adjustable rear mirror with electric heating

Electric air conditioning

Power windows & Electric tilt cab

Multi-function steering wheel

# 02 Core Advantages



## Exceptional Power

High torque, power surging

- ◆ The German-engineered Deutz D13 engine, boasting an impressive 485 HP and 2350 N·m, offers **superior power advantages over competitors**



## High Reliability

**≥1 million km service life**

- ◆ Vehicle components boast improved performance, with rust-proof, dust-proof and waterproof rating **meeting C5 standard**
- ◆ Vehicle passed million-kilometer durability validation, proving **service life ≥1 million km**



## High Security

**30% vehicle's active safety**  
performance enhancement

- ◆ Standard in ABS+ASR, and driver fatigue monitoring, intelligent technologies boost the vehicle's **active safety performance by 30%**
- ◆ The cab and body feature an all-steel integrated design, with safety performance meeting and exceeding ECE R29 requirements. The paint film thickness is significantly higher than industry standards, delivering **superior corrosion resistance and durability**



## High Passability

**≥530 mm** bumper ground clearance

- ◆ The high-mounted bumper features a ground clearance of up to 530 mm, **ensuring excellent passability in complex road conditions**

# 02 Core Advantages

## Gold-Powered Drive System

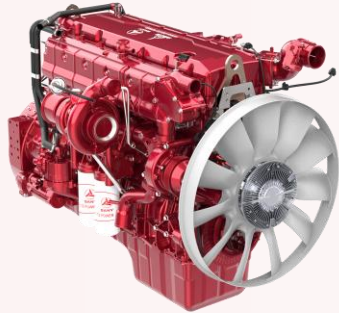

SANY Deutz engine

- ✓ DEUTZ, a century-old brand, features the European latest advanced technology with strong overload capacity and superior durability
- ✓ High-efficiency turbocharger and high explosion pressure combustion technology deliver stronger power output, with more robust performance during startup and sudden acceleration

## Efficient transmission performance & Stable output



FAST gear transmission

- ✓ FAST's new-generation integrated automatic transmission balances power performance across both high and low speed ranges
- ✓ High-precision gear grinding technology achieves a transmission efficiency of up to 99.8%
- ✓ Equipped with economic/sport dual driving modes, it features smooth shifting and easy operation



FANGSHENG /  
HANDE axle

- ✓ FANGSHENG/HANDE axle features superior load capacity, high quality and reliability
- ✓ A broad range of gear ratio options enables adaptation to diverse operating conditions, including highway and national road scenarios

# 03 Application Scenarios & Cases



## Gravel transportation from construction site to urban area

Segment market

GCW

Maximum speed

Transportation scenarios

Transportation distance

Gravel transportation from construction site to urban area

45 t

89(speed limited) / 120 km/h (speed unlimited)

Gravel, ores, earthwork, cement, etc

200km-1500km



Highway gravel transportation



Highway cement transportation

# 03 Application Scenarios & Cases



Countries : Saudi Arabia

Scenarios : Powder tank transportation

Number of Deliveries : 20 units

# 03 Application Scenarios & Cases



Countries : Saudi Arabia

Scenarios : Sand & gravel transportation

Number of Deliveries : 20 units

# 04 Technical Support & Services

## A. Service network



### SANY Efficient Service Supply Network

24/7 Service Online



**1,700+**

Overseas Service Centers

**7,000+**

Professional Service Staff

**24h**

24/7 Always Online

### Prompt SANY Standard Service Response

“12127” Service Target



**1** quarter Respond

**2** hours Arrival

**1** day General Issues Solved

**2** days Complaint Issues Solved

**7** days Legacy Issues Solved

### Parts Support

“1790” Parts Target



**1** day Downtime Parts Shipped within 1 Day

**7** days Urgent Parts Shipped within 7 Days

**90%** Local Parts Availability

# 04 Services Support

## B. Service Policy

### A. Vehicle Warranty Policy

For SANY trucks in overseas markets, the standard warranty period for all vehicle parts (excluding critical components and special warranty items) is **two-year with unlimited mileage**

### B. Key Components Warranty Policy

#### For Standard Model

- **Automatic transmission assembly**  
(Casting Parts follow the base warranty period): **36 months**
- **Manual transmission assembly**  
(Housing Parts follow the base warranty period): **36 months**



Transmission

- Lifting Axle, Support Axle Tube & Axle Housing Assembly, Bearing Block, Transfer Case Cover, Transfer Case, Oil Seal Seat: **36 months**



Axles

- Basic components(excluding Crankshaft, Camshaft, Connecting Rod, Flywheel Housing, Gear, Timing Gear Chamber): **36 months**



engine

#### For Super Model

- Automatic transmission assembly (Casting Parts follow the base warranty period): **24 months**

- Lifting Axle, Support Axle Tube & Axle Housing Assembly, Bearing Block, Transfer Case Cover, Transfer Case, Oil Seal Seat: **24 months**

- Basic components(excluding Crankshaft, Camshaft, Connecting Rod, Flywheel Housing, Gear, Timing Gear Chamber): **24 months**

### C. Parts Warranty Policy

Components purchased by customers through parts stores or service centers are covered by a **6-month** SANY parts warranty

For specific component warranty periods, please refer to *SANY Detailed Rules for Quality Warranty Periods*.

t h a n k s

**SANY TRUCK**



[www.sanyglobal.com](http://www.sanyglobal.com) | [www.sanytruck.com/intl/](http://www.sanytruck.com/intl/)



Follow SANY Group



Follow SANY TRUCK